

Take Control.
ION
Technologies

A division of Metropolitan Industries, Inc.



SHS50

1 YEAR
WARRANTY



Sewage Pump

- Septic tank effluent
- Light Commercial sewage
- Residential sewage
- High-capacity sump



37 Forestwood Dr., Romeoville, IL 60446
www.ionproducts.net [815] 886-9200

SHS50

Sewage Pump

System Specifications

Typical Applications	<ul style="list-style-type: none">• Septic tank effluent• Commercial sewage• Residential sewage• High-capacity sump
Maximum Capacity	Up to 150 GPM
Maximum Head	Up to 50'
Electrical Data	115 V, 1 Ø, 14.2 FLA, 60 Hz
Motor Data	½ HP, 3450 RPM
Intermittent Liquid Temperature	140° F
Recommended Minimum Basin Size	24" x 30"
Manual Operation	M: Manual (standard)
Automatic Operation	i: Ion Digital Level Control W: Wide angle switch
Materials of Construction	Cast iron
Impeller	Cast iron
Power Cord	20' Standard
Discharge	2" NPT (3" optional)
Solids Handling	2"

Pump Dimensions

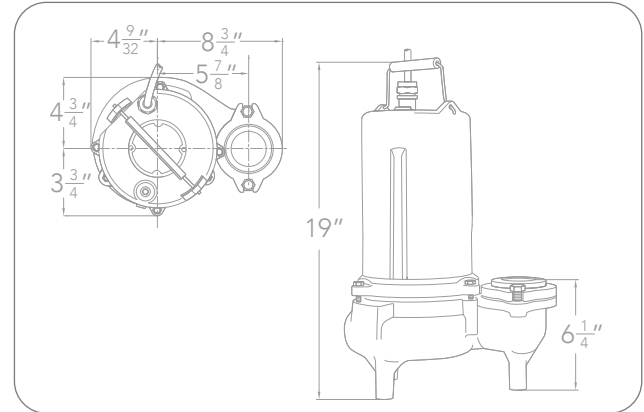

Pump Performance

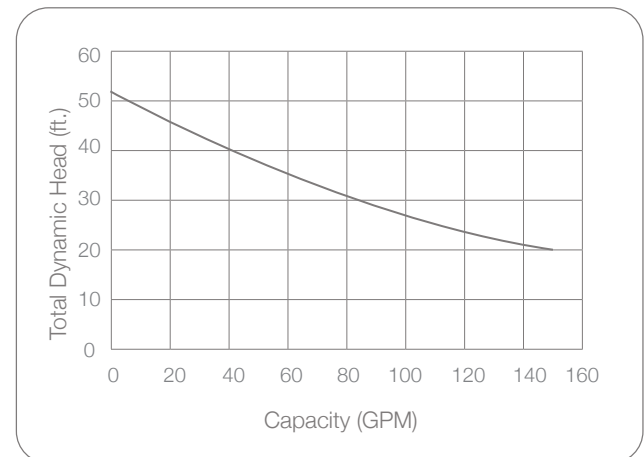

Features

- Carbon ceramic mechanical seal
- Automatic reset thermal overload for maximum protection
- Lower single-row ball-bearing construction
- 1 year warranty