

Take Control.
ION
Technologies

A division of Metropolitan Industries, Inc.



SE40-60i

3 YEAR
WARRANTY



Sewage Pump

- Septic tank effluent
- High capacity sump
- Residential sewage
- Light commercial sewage



37 Forestwood Dr., Romeoville, IL 60446
www.ionproducts.net [815] 886-9200

Patent No. 8,591,198

SE40-60i

Sewage Pump

System Specifications

Typical Applications	• Septic tank effluent
	• High capacity sump
	• Commercial sewage
	• Residential sewage
<hr/>	
Maximum Capacity	
SE40:	Up to 117 GPM
SE60:	Up to 174 GPM
<hr/>	
Maximum Head	Up to 26'
<hr/>	
Electrical Data	
SE40M-1:	115 V, 1 Ø, 11 FLA, 60 Hz
SE60M-1:	115 V, 1 Ø, 12 FLA, 60 Hz
SE60M-01:	208 V, 1 Ø, 7.5 FLA, 60Hz
SE60M-21:	230 V, 1 Ø, 6.0 FLA, 60Hz
SE60M-23:	230 V 3 Ø, 4.5 FLA, 60Hz
SE60M-43:	460 V, 3 Ø, 2.3 FLA 60Hz,
SE60M-03:	208 V, 3 Ø, 4.7 FLA, 60Hz
<hr/>	
Motor Data	
SE40:	4/10 HP, 1750 RPM
SE60:	6/10 HP, 1750 RPM
<hr/>	
Recommended Minimum Basin Size	18" x 30"
<hr/>	
Automatic Operation	i: Ion Digital Level Control (standard)
	W: Wide angle switch
Manual Operation	M: Manual
<hr/>	
Materials of Construction	Cast iron
<hr/>	
Impeller	Cast iron, 2-vane
<hr/>	
Power Cord	20' Standard
<hr/>	
Discharge Size	2" NPT (3" NPT optional)
<hr/>	
Solids Handling	2"

Pump Dimensions

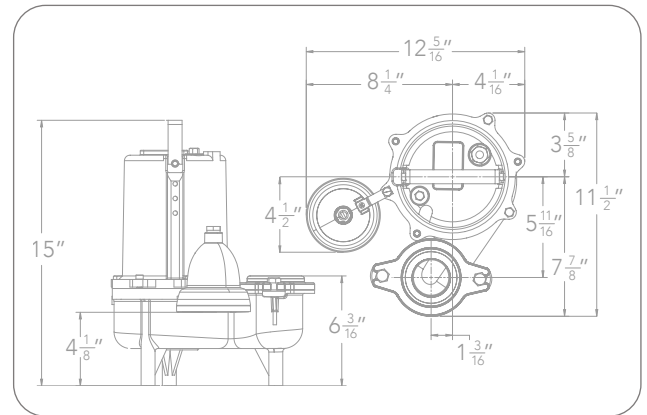

Pump Performance

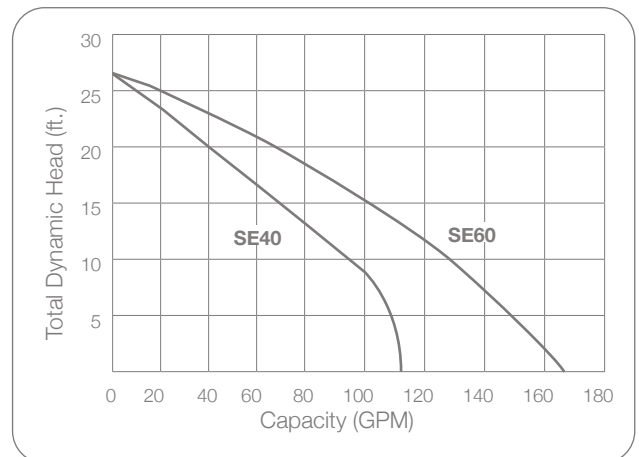

Features

- Carbon ceramic mechanical seal
- Oil-filled high efficiency PSC motor
- Uses single-row ball-bearing construction
- Ion® digital level control piggyback switch has no moving parts (standard)
- 3 year warranty