

Take Control.
ION
Packages

Now available
with optional
factory installed
Ethernet Module.



Ion® Endeavor BA50

All parts included to install a smart controller with sensors & pump



- First of a kind 115 volt standard plug in receptacle, dual pump run and alternating controller for residential and commercial applications
- Ion® sensors communicate with controller to provide controller based turn on level adjustment from 2.5" to 72" for optimal pump operation
- Track critical information through the panel based display, including switch failure, pump amp draw, water level and more
- Wide range of communication options available



37 Forestwood Dr., Romeoville, IL 60446 www.ionproducts.net [815] 886-9200

Patents Pending, Patent No. 8,591,198

Ion® Endeavor BA50

System Specifications

| | |
|--------------------------------|--------------------------------------------------------------------------------------|
| Typical Applications | <ul style="list-style-type: none">• Basement sump• Dewatering |
| Maximum Capacity | Up to 78 GPM |
| Maximum Head | Up to 29' |
| Electrical Data | 115 V, 1 Ø, 5.8 FLA, 60 Hz |
| Motor Data | ½ HP, 3450 RPM |
| Recommended Minimum Basin Size | 18" x 24" |
| Manual Operation | M: Manual |
| Materials of Construction | Cast iron & stainless steel |
| Impeller | Cast iron vortex |
| Power Cord | 10' Standard (20' optional) |
| Discharge Size | 2" NPT |
| Solids Handling | ½" |

BA50 Sump Pump Dimensions

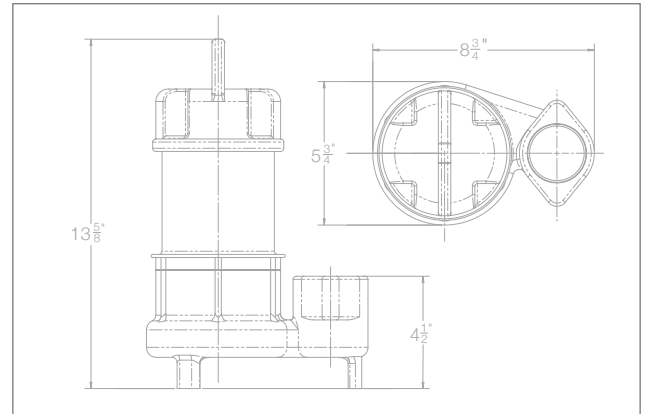

BA50 Sump Pump Performance

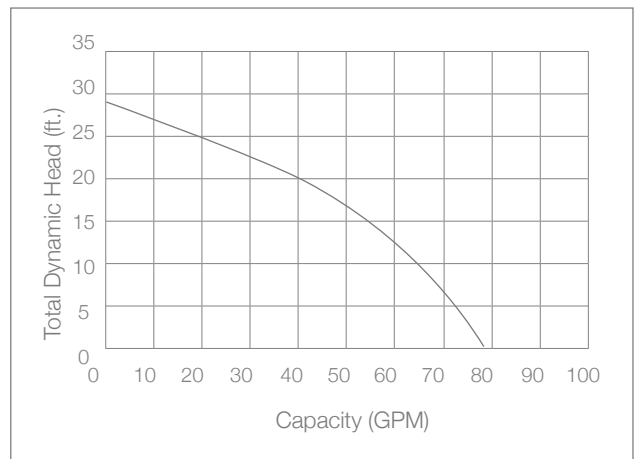

Features

- Energy efficient motor
- Carbon ceramic mechanical seal
- Thermal overload protection
- Ion® digital level control sensor has no moving parts (standard)
- Stainless steel screen prevents debris from entering the pump
- 3 year warranty