

Take Control.  
**ION**  
*Technologies*

A division of Metropolitan Industries, Inc.



# BA33i+

Sump Pump With Built-In High Water Alarm

- Basement Sump
- Dewatering

**3 YEAR**  
RESIDENTIAL  
WARRANTY



37 Forestwood Dr., Romeoville, IL 60446  
www.ionproducts.net [815] 886-9200

Patent No. 8,591,198,  
9,033,686 and 9,680,401

# BA33i+

Sump Pump With Built-In High Water Alarm

## System Specifications

Typical Applications	<ul style="list-style-type: none"><li>• Basement sump</li><li>• Dewatering</li></ul>
Maximum Capacity	Up to 68 GPM
Maximum Head	Up to 25'
Electrical Data	115 V, 1 Ø, 4.5 FLA, 60 Hz
Motor Data	1/3 HP, 3450 RPM
Recommended Minimum Basin Size	18" x 24"
Automatic Operation	i+: Ion+ (standard)
Materials of Construction	Cast iron & stainless steel
Impeller	Thermoplastic vortex
Power Cord	10' Standard
Discharge Size	1½" NPT
Solids Handling	½"

## Pump Dimensions

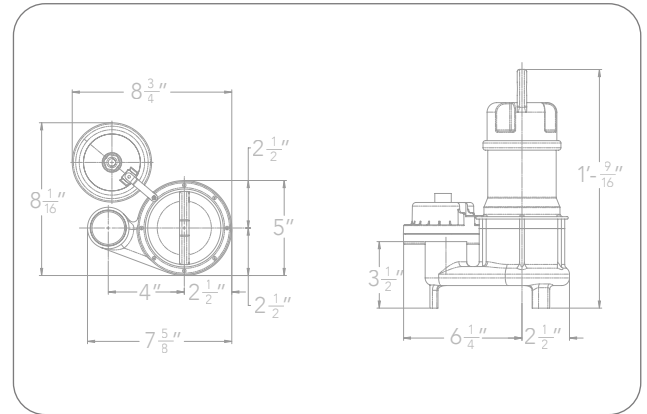

## Pump Performance

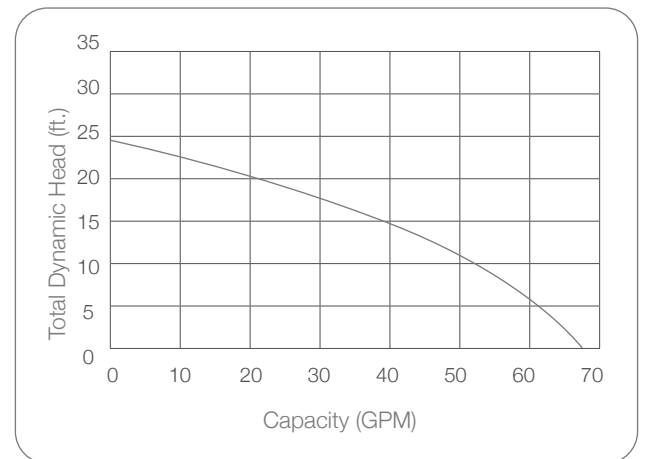

## Features

- Energy efficient motor
- Carbon ceramic mechanical seal
- Thermal overload protection
- Ion+® digital level control piggyback switch with alarm has no moving parts (standard)
- Stainless steel screen prevents debris from entering the pump
- 3 year residential warranty